

DICE Mini / TCD2210

PRELIMINARY DATA Rev 0.75

SINGLE CHIP IEEE 1394 AUDIO SOLUTION FOR MI APPLICATIONS

- Complete **IEEE1394**, **AES3**, **ADAT®**, **I²S**, **I⁴S** and **I⁸S** transceiver
- **IEC 61883-6** Compliant Audio Streaming
- Optional **OGT** connection management support
- +1.8V core supply, +3.3V I/O
- A total of 32 IEEE 1394 FireWire® audio channels
- No-jitter solution using patented **JET™ PLL** technology
- **AES** receiver/transmitter handling 8 channels in each direction at any rate.
- Dual **ADAT** receiver/transmitter with **S-MUX** support for total 8 channels @ 96kHz
- Glueless connection of AD/DA converters (16 channels in each direction)
- 18 by 16 channel hardware mixer
- Hardware meter support for all channels
- **ARM™** 32 bit RISC processor
- IEEE 1394 Link Layer Controller
- Available in QFP-128 package
- Patented Low jitter clock recovery

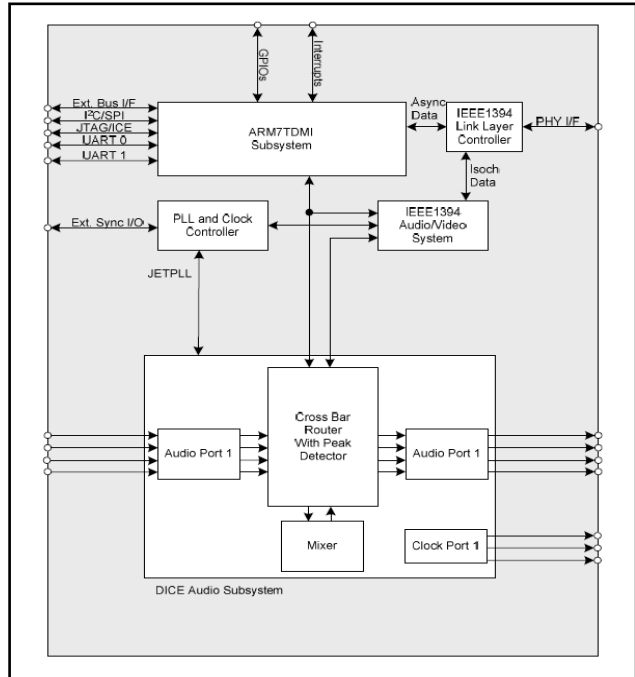

DICE Mini is a monolithic CMOS ASIC capable of receiving and transmitting up to 16 channels of audio data in accordance with the **IEEE 1394** standard.

The new DICE Mini technology simplifies the interface to IEEE 1394 and other popular digital audio formats, while it maximizes the clocking accuracy of audio samples.

Unique to the DICE Mini is patented **JET™ PLL** technology and a 18x16 hardware mixer with hardware metering support.

With its high integration, **JET™ PLL** technology, and support of IEEE 1394b DICE Mini gives FireWire the versatility necessary for professional and consumer audio markets. Now low cost CAT-5 cable has 100 meter support at the full data rates of all popular digital audio formats.

DICE Mini's broadband streaming engine handles all aspects of moving data without placing realtime load on the host processor (**ARM™**).

The full **SDK** supports Hardware Abstraction Layer (**HAL**) libraries and **IEEE 1394** stacks with support for **OGT**, **AVC** (Class Compliant) and **TCP/IP**.

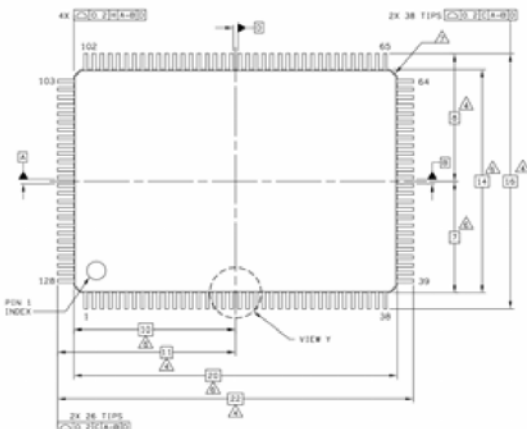

For further information contact:

Chip Features

CPU core

- Full 32-bit ARM7TDMI RISC processor
- 32-bit internal bus
- 16-bit Thumb mode
- 32 Kb 0 wait state RAM
- 15 general-purpose 32-bit registers
- 32-bit program counter and status register
- 5 supervisor modes, 1 user mode
- External Bus Interface (EBI)
- Remap of Internal RAM during boot.

I2C Interface

- Standard and Full Speed support
- Slave mode with address match logic
- Master Mode
- 10 bit and 7 bit addressing mode
- 16 deep FIFO buffer

SPI Interface

- Master and Slave mode
- GPIO used for Slave Select
- Interrupt on Byte transfer complete

Dual Timer Unit

- 32 bit counter
- Free running and user-defined count
- Interrupt on counter wrap
- Clocked by CPU clock

Watch Dog

Dual Universal Asynchronous Receiver Transmitter (UART)

- Industry standard 16550 Compliant
- 16 deep receive and transmit FIFO's
- Supports all standard RS232 Rates
- Supports MIDI rate

General Purpose Input Output (GPIO)

- 8 individual ports
 - Each port configurable as input or output

- Each port configurable for level or edge sensitive interrupts

Quad Rotary Encoder Interface (Gray Decoder)

- individual rotary encoder counters
- 8 bit signed counter per port
- Configurable interrupt on value change

IEEE 1394 Link Layer Controller (LLC)

- IEEE 1394a compliant LLC
- Compliant PHY interface
- Support for isolation barrier
- 512x32 FIFO for asynchronous communication

Digital Interface Communication Engine (DICE)

- JETTM PLL
- Cross-bar router with peak detector
- 1 Generic Audio Receive Port (16 ch. per port)
 - 4 x 2 ch. of I²S (32KHz to 192KHz)
 - 4 x 4 ch. of I⁴S (32KHz to 192KHz)
 - 2 x 8 ch. of I⁸S (32KHz to 96KHz)
 - 4 x 2 ch. of AES (32KHz to 192KHz)
 - 2 x 8 ch. of ADAT (8 ch. @96KHz, 4 ch @ 192KHz)
- 1 Generic Audio Transmit Port (16. ch per port)
 - 4 x 2 ch. of I²S (32KHz to 192KHz)
 - 4 x 4 ch. of I⁴S (32KHz to 192KHz)
 - 2 x 8 ch. of I⁸S (32KHz to 96KHz)
 - 4 x 2 ch. of AES (32KHz to 192KHz)
 - 2 x 8 ch. of ADAT (8 ch. @ 96KHz, 4 ch @ 192KHz)
- ARM Audio Receiver/Transmitter, 8 channels (32KHz to 192KHz)
- IEC 61883-6 Isoc. Receiver, 16 channels
- IEC 61883-6 Isoc. Transmitter, 16 channels
- Mixer 18x16 ch. (18x4 ch. @ 192kHz)

Power and operating voltage

- 900 mW maximum, 700 mW typical (TBD)
- 3.3 volts - I/O
- 1.8 volts – core

For further information contact:

TC Applied Technologies • 156 Duncan Mill Road, Suite 1A • Toronto, ON • M3B 3N2, Canada
 Phone: +1 (416) 444-1394 • Fax: +1 (416) 444-9394 • E-main: info@tctechnologies.tc • Web: www.tctechnologies.tc