

**TC** | APPLIED  
TECHNOLOGIES

DESIGNING WITH





# Welcome

Welcome to Designing with DICE. This booklet is written to provide an overview of the DICE family of Firewire chips created by TC Applied Technologies (TCAT). DICE chips are designed for Professional Audio uses in recording, broadcasting, installation and live sound products – places where audio quality and performance matter most. Each DICE chip is a system on a chip including microprocessor, JetPLL™, support for multiple legacy digital audio formats, and support for I/O, controls and displays. Key audio elements such as the standards-compliant streaming engine are implemented in hardware rather than firmware to insure minimum latency. Pro Audio products designed with DICE chips can be simple and inexpensive when it comes to the overall system, yet first-class in audio performance.

TCAT was established in 2003. The company's foundations were created at world-renowned TC Electronic in Denmark. A digital audio pioneer, TC Electronic (TC) was established in 1976. TC's first proprietary digital audio chips appeared in its products in 1996. TC recognized early that Firewire offered the potential to create powerful, flexible networked audio systems having low latency and high bandwidth. Years of R&D investment by TC are the basis of the DICE chip series. In 2003 TCAT was created to bring that technology to completion and to deliver the promise of Firewire in chip-form to the Pro Audio community. The company is established as an independent business unit and is based in Canada.

## Why Firewire?

Firewire (aka IEEE-1394) is the Pro Audio digital audio transport protocol of choice because it offers:

- A true network including peer to peer communication – any device to any device, unmediated by a computer
- Quality of service – no drop-outs
- Extremely low latency – a system delay of 450us device to device
- High channel count – up to 96 channels at 96KHz (1394a)
- Flexibility – daisy chain topology
- Multiple Sources and Multiple Destinations – all devices on the network 'see' all data
- Modular Expansion – up to 63 devices on a network
- Power on the bus – 8-33 volts/1.5 amps
- An industry standard protocol that is being advanced and supported by major players in the CE industry. Firewire has a strong present and a strong future. 1394c is currently being defined by the 1394 Trade Association.

It lets designers create systems with:

- Scaleable Signal Processing
- Scaleable Amplification
- Convenience and Simplicity
- Invisibility
- Reliability; and
- Flexibility.

Firewire based systems allow customers freedom of choice. They can buy what they need and expand their systems piece-by-piece rather than having to discard an old system and completely retool when, for example, they need to add extra channels.

A single Firewire jack carries multiple channels of audio and MIDI while simultaneously also being able to carry Video and even file transfers between computers.

## Why DICE?

The DICE family of chips is designed by a team whose experience and skills were gained designing some of the most innovative products in Pro Audio. The features and capabilities of the DICE family reflect this. While each chip is designed for different uses, the family shares a common set of capabilities and features:

- Speed and Low Latency – all time-critical functions are executed in hardware, not firmware. Typical 1394 firmware implementations on other chips add 2ms or more of latency compared with 225us for the DICE chips;
- Phase alignment – The streaming engine with the help of the JetPLL™ allows for phase alignment of as low as 40ns between devices;
- Low jitter clock recovery – JetPLL™ is a patented technology that offers the lowest audio-band jitter available – some key numbers are 20ps RMS audio band jitter and jitter reduction of more than 60dB (1ns becomes 1ps).
- Compliance with a standard – IEC61883-6 streaming engine

- No-fee software and drivers

## How DICE?

The DICE family is specifically designed to get audio into, around and out of a Firewire system. It is designed to do so quickly without adding material latency; without ruining clocks; without adding jitter and compromising sync; and without requiring a lot of extra external devices such as PLLs, ADAT/AES transmitters and receivers etc.

The basic DICE system consists of:

- DICE – manages signal routing, cleans received clocks using its JetPLL™, and gets into and out of the Firewire zone using a hardware-based IEC61883-6 streaming engine (this is 1394 standards-compliant unlike some other approaches found in Pro Audio products today). Note that the core of DICE is an ARM-7 50MHz RISC processor which is available for designer use.
- 1394 PHY – Connects to the internal 1394 Link Layer converting the output of the streaming engine to switched voltages that run on cables
- Flash ROM – Contains the boot-sector, firmware and settings. The ARM initially boots from this device and copies the user application to SDRAM.
- SDRAM – Used for the running firmware code and for related data structures.
- Converters - DACs and ADCs for analog interface
- Optional DSP/FPGA – External signal processing or mixing if more than the internal ARM-7 core is needed.

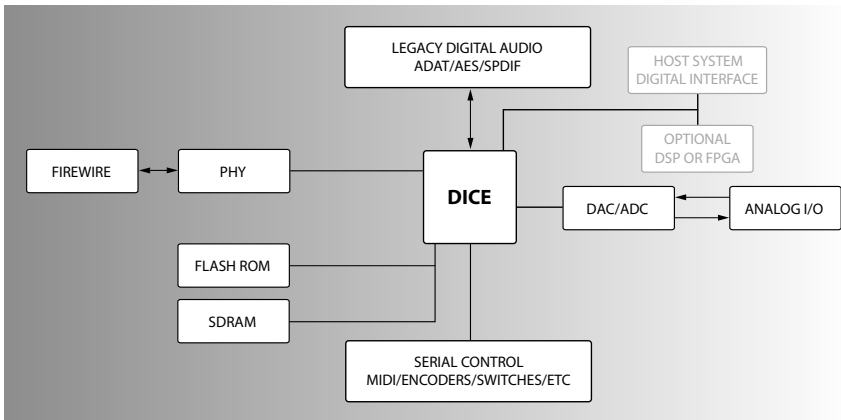

fig. 1 DICE overview

# DICE Jr

DICE Jr is typically used in designs where a moderate combination of analog and legacy digital connections are needed. Examples would include a mid-priced I/O box or audio mixer (only two possible applications are shown below). Unlike DICE II, DICE Jr is significantly smaller and has fewer pins, thus all audio formats can not supported simultaneously. Instead, the port lines are configurable, allowing the designer to choose how the two audio ports are going to be used. In order to further aid in making small, efficient and more inexpensive products, the DICE Jr also has a 18x16 mixer with peak level detection implemented on-chip and in hardware, not firmware (please see the Summary 'More Dice?' section for more information on the mixer feature).

It is designed for applications requiring:

- Mid-channel count – up to 32 in/32 out
- Choice of connection to legacy digital formats (ADAT, AES, SPDIF)
- External DSP or FPGA to perform algorithms/processing
- Multiple external encoders/switches – for example, 24 LEDs, 6 switches, 1 encoder plus an LCD display

DICE Jr has two configurable audio ports. Each audio port has 4 lines that can be individually configured between I2S, I8S, AES or ADAT as follows:\*

PORT 0				
1	I <sup>2</sup> S	I <sup>8</sup> S	AES0	-
2	I <sup>2</sup> S	I <sup>8</sup> S	AES1	-
3	I <sup>2</sup> S	-	AES2	ADAT0
4	I <sup>2</sup> S	-	AES3	ADAT1
PORT 1				
1	I <sup>2</sup> S	I <sup>8</sup> S	AES0	-
2	I <sup>2</sup> S	I <sup>8</sup> S	AES1	-
3	I <sup>2</sup> S	-	AES2	-
4	I <sup>2</sup> S	-	AES3	-

\* please note that there is a maximum of 4 simultaneous AES channels.

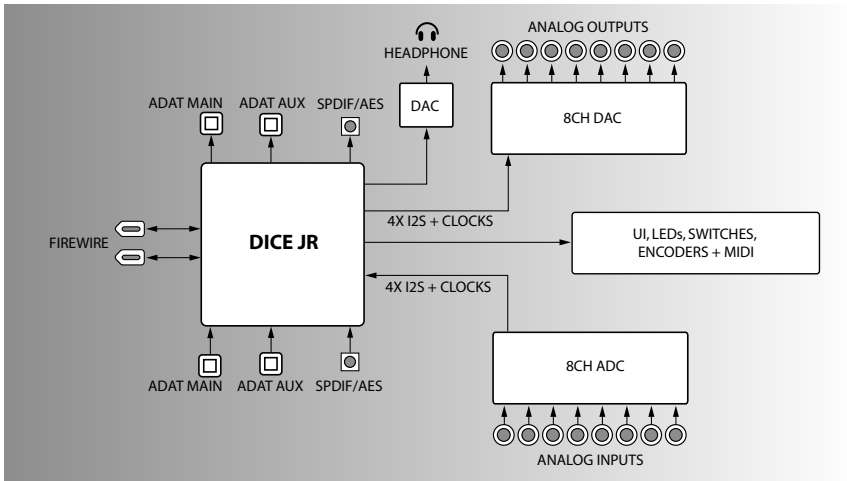

fig.2 Basic DICE JR based digital I/O interface with 18 inputs and 16 outputs @ 44.1KHz - 96KHz (14/14 @ 192KHz)

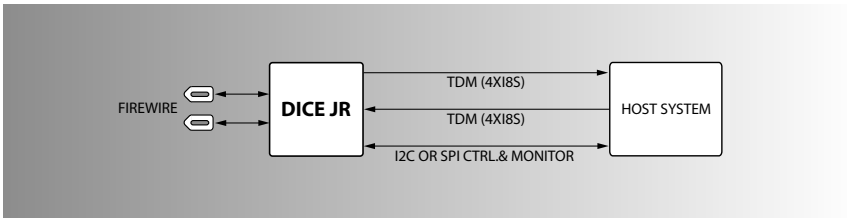

fig.3 Basic DICE JR based digital I/O expander for mixers, keyboards, etc. 32/32 (18/8 @ 192KHz)

## DICE Mini

DICE Mini is the smallest and simplest DICE chip. It is designed as a low-channel-count bridge between Firewire and analog/digital. For example, DICE Mini works well as the Firewire connector for a node in a network, or for a bridge-point to analog or legacy digital in a distributed audio network (only two possible applications are shown below).

DICE Mini also has the fewest pins. It has a single audio port whose lines are configurable, allowing the designer to choose how this port's four audio lines are going to be used. In order to further aid in making small, efficient and more inexpensive products, the DICE Mini has a 18x16 mixer with peak level detection implemented on-chip and in hardware, not firmware (please see the Summary section for more information on the mixer feature in DICE Mini).

It is designed for applications requiring:

- Low-channel count – up to 16 in/16 out
- Choice of connection to legacy digital formats (ADAT, AES, SPDIF)
- External DSP or FPGA to perform algorithms/processing
- Multiple external encoders/switches – for example, 12 LEDs, 4 switches

Unlike DICE Jr, DICE Mini has only one audio port. This single audio port has 4 lines that can be individually configured between I2S, I8S, AES or ADAT as follows:

PORT 0				
1	I <sup>2</sup> S	I <sup>8</sup> S	AES0	-
2	I <sup>2</sup> S	I <sup>8</sup> S	AES1	-
3	I <sup>2</sup> S	-	AES2	ADAT0
4	I <sup>2</sup> S	-	AES3	ADAT1

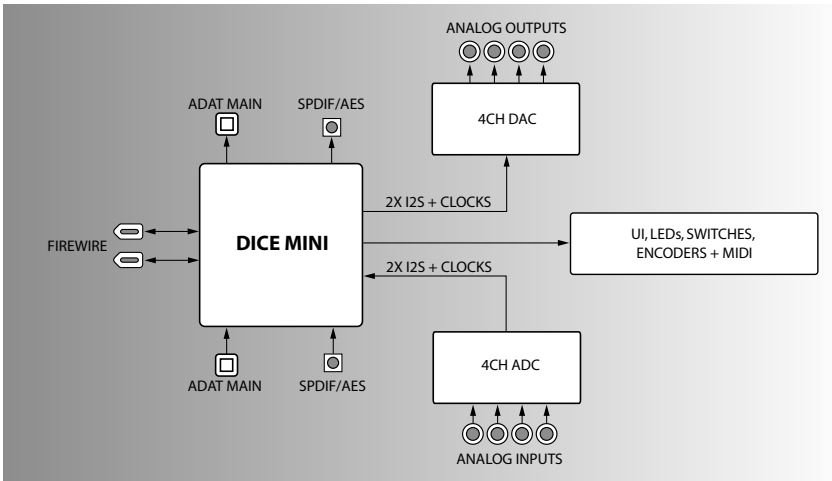

fig.4 Basic DICE Mini based I/O interface with 14 inputs and 14 outputs @ 44.1KHz, 10/10 @ 96KHz (8/8 @ 192KHz)

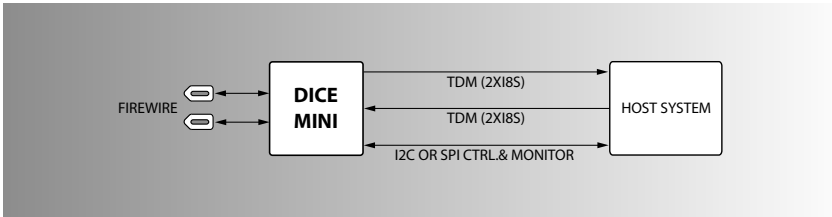

fig.5 Basic DICE Mini based I/O expander for mixers, keyboards, etc. 16/16 (44.1KHz to 192KHz)

## More DICE?

### Chip Comparisons

In terms of channels and other high-level features, the following table allows comparison of the three DICE chips.

	CHANNELS I/O	JetPLL™?	CLOCK DOMAINS	NUMBER OF PINS/PACKAGES	OTHER
DICE JR	32/32	YES	1	144 PIN LQFP	DUAL CONFIGURABLE AUDIO PORT
DICE MINI	16/16	YES	1	128 PIN QFP	SINGLE CONFIGURABLE AUDIO PORT

### Application Configurations

For comparison, here are just a few example configurations of DICE Jr and DICE Mini.

EXAMPLE CONFIGURATIONS	DICE JR	DICE MINI
AD/DA OVER 12S	16CH AD/DA, NO OTHER I/O	8CH AD/DA, NO OTHER I/O
AD/DA OVER 18S	16CH AD/DA, 16(8)CH ADAT, 8CH AES	8CH AD/DA, 2CH AES, 16(8) CH ADAT
DIGITAL I/O'S	16(8)CH ADAT, 8CH AES	16(8)CH ADAT, 4CH AES, NO OTHER I/O
MIXED (12S AD/DA)	8CH AD/DA, 2CH AES, 16(8) CH ADAT	4CH AD/DA, 2CH AES, 8(4)CH ADAT*
MIXED (18S AD/DA)	16CH AD/DA, 8CH AES, 16(8) CH ADAT	8CH AD/DA, 1CH AES, 16(8) CH ADAT

### The ARM-7 Core

Almost all of the processing power of the ARM-7 50MHz CPU on each DICE chip is available thanks to the hardware streaming architecture of the DICE family. Neither the ARM processor nor its memory are kept busy with the audio streams. This leaves the CPU 99% free to be used for host and UI functions in your designs. It can drive all UI, calculate coefficients for DSP, load FGPA code and handle MIDI from various sources such as the two UARTS or the Firewire MIDI interfaces. The SDK from TCAT comes free with the tools and documentation needed.

### DICE JR/Mini Mixing Engine

The mixer is a full 18x16 mixer with 288 mix points. It is full 24 bit on the audio path with 16 bit unsigned coefficients allowing for 12dB of gain (fixpoint 2:14). The mixer has a saturation limiter on each summing bus with sticky overload indication.

With this flexible engine an array of mixing applications can be realized, for example:

- Full 18 channel mixer with 8 independent stereo mix busses. This can be viewed as 8 individual mixers each having 18 channels with level and pan and a final level for each

of the 8 stereo outputs. The 18 channels can come from any interface on the chip including play back channels from DAW (Firewire channels) The routing can be changed at run time with a simple write to a register.

- Full 18 channel mixer with AUX Send busses. This is basically a full 18 channel mixer with level, pan and up to 14 mono aux sends (7 stereo). It is the same mixer as above but with a different UI on top.
- Full 18 channel 4.0, 5.1, 7.1... surround mixer. Each of the 18 input channels has level, XY pan. The remaining output channels can be used either for creating several surround mixes or for AUX sends.

#### JetPLL™

JetPLL™ is a patent-pending jitter elimination technology found in each DICE chip. It is designed into DICE chips to ensure that products using DICE can deliver both exceptional connectivity and the highest quality audio.

Every device in a Firewire network must dynamically recreate and synchronize its own clock locally as it receives a clocking signal from its chosen source. The difference between clock frequencies of devices across a network creates audio band jitter, and this shows up as collapsing stereo fields, reduced dynamic range and, at worst, even mobile phone audio quality. The typical solution to this problem is to either accept lower audio quality by using inexpensive solutions, or to design in expensive VCXOs or sample rate converters. JetPLL™ delivers outstanding performance when compared to these complex and more expensive methods.

#### Associations & Standards

TCAT is actively involved with organizations involved with 1394, and encourages your involvement, too! To learn more about where Firewire is going both inside and outside of Pro Audio, we encourage your investigation of and participation in the following organizations:

The Audio Engineering Society ([www.aes.org](http://www.aes.org))

The 1394 Trade Association ([www.1394TA.org](http://www.1394TA.org))

The High Definition Audio Video Network Alliance or HANA ([www.hanaalliance.org](http://www.hanaalliance.org))

## Glossary

ADAT – Alesis Digital Audio Tape Lightpipe protocol. Originally introduced on Alesis ADAT recorders, this protocol transfers 8 tracks on a single fiber optic cable. Many manufacturers offer ADAT connectivity on their products because of the number of channels offered on a single connector (compared to SPDIF or AES/EBU which support only two channels).

ADC – Analog to digital converter.

AES – Used in this document to refer to the AES3 standard by the Audio Engineering Society (AES) and the European Broadcasting Union (EBU). It is a two-channel standard used for moving digital audio signals between pro audio products. Devices are interconnected using XLR connectors and balanced cables.

ARM-7 – 50MHz Reduced Instruction Set Computer (RISC) processor at the heart of each DICE chip. Designed by and licensed from ARM Holdings plc, the ARM-7 comes with development tools that allow designers to easily customize the functions of a DICE chip.

DAC – Digital to analog converter.

DICE – Digital Interface Communications Engine. A trademark of TC Applied Technologies Ltd.

Flash ROM – Non-volatile read-only memory that can be reprogrammed.

FPGA – Field Programmable Gate Array. A general purpose chip whose logic and connects can be programmed. Unlike an ASIC or Application Specific Gate Array which is designed to only perform one set of predetermined functions, an FPGA is programmable and highly flexible. Connected to a DICE chip, an FPGA may perform certain additional I/O or signal processing functions in addition to performing other functions in a larger product.

I<sup>2</sup>S – Pronounced 'I-Squared-S' derived from 'Integrated Interchip Sound' or 'Inter-IC Sound' which is a serial interface standard used for moving digital audio between audio devices in an electrical circuit. This connection has a 2 audio channel capacity.

I<sup>2</sup>C – Pronounced 'I-Squared-C' derived from 'Inter-Integrated Circuit'. I<sup>2</sup>S is used to move low-speed control data to peripherals attached to the DICE chip. For example, control data between the DICE chip and an ADC.

I<sup>4</sup>S/ I<sup>8</sup>S – Like I<sup>2</sup>S but with an 4/8-audio-channel capacity. Also known as DSAI, TDM, ESSI.

IEC61883-6 – Standard protocol for streaming audio over Firewire.

IEEE-1394 – Official name for Firewire. Also known as i.Link. A high-speed, isochronous, realtime digital network with guaranteed Quality of Service.

**Jitter** – When used in discussions concerning Digital Audio Networking, this typically refers to Audio Band Jitter. Caused by the variations in the timing of digital clocks controlling audio in devices in the digital system, packets being streamed can arrive with varying delays. Jitter appears as audio degradation including reduced dynamic range and collapsed stereo fields. It is normally solved through the introduction of a PLL.

**Latency** – in a digital audio system, latency refers to the delay between when an audio event actually occurs and when it is present at a given point. For example, we could refer to round-trip latency in a digital recording system and would measure the time from the creation of a sound in the analog domain, through its conversion to digital at the I/O box, its trip to the computer-based recorder, back to the I/O box and its final conversion to analog. Typically, human hearing perceives latency when the delay in such a system exceeds 10ms.

**LED** – Light Emitting Diode.

**MIDI** – Musical Instrument Digital Interface. The protocol that lets electronic instruments such as synthesizers, samplers, sequencers, and drum machines from any manufacturer communicate with each other and with computers.

**PLL** – Phase Locked Loop – used as a way to stabilize a generated signal to reduce jitter.

**Quality of Service** – General networking term referring to the protocol offering different Quality of Service. In general the quality can refer to such things as priority, security, minimum delivery time or guaranteed bandwidth. IEEE 1394 offers two primary qualities of service; Asynchronous and Isochronous. Isochronous implies that a certain amount of bandwidth will be guaranteed within a defined time interval. This service can be used to deliver realtime streams such as audio and video with guaranteed delivery within a guaranteed time.

**SDK** – Software Developers Kit.

**SDRAM** – Synchronous Dynamic Random Access Memory.

**SPDIF** – Sony/Philips Digital Interface Format. Consumer version of AES/EBU.

**SPI** – Serial Peripheral Interface.

**SRC** – Sample Rate Converter.

**TDM** – Time Division Multiplex, a general term for multiplexing data in fixed timeslots. In this document TDM is used for a 4 or 8 channel serial transmission of digital audio.

**Topology** – In this discussion, topology refers to the way a network can be physically connected. Firewire can be connected in a star, daisy chain, tree or combinations of those. Modern Ethernet and USB devices are always endpoint devices and therefore require bridges or hubs to create star topologies.

**UART** – Pronounced “you art”, it stands for Universal asynchronous receiver/transmitter.

Part of an IC that offers serial communications (like MIDI or RS-232).

UI – User Interface.



**[www.tctechnologies.tc](http://www.tctechnologies.tc)**

TC Applied Technologies Ltd. 156 Duncan Mill Road, Toronto, ON M3B 3N2 Canada  
email: [info@tctechnologies.tc](mailto:info@tctechnologies.tc) phone: (416)444-1394 fax: (416)444-9394